

Installation manual

**W465H, W475H/S, W485S, W4105H/S,
W4130H/S, W4180H/S, W4240H,
W4250S, W4300H, W4330S**

Clarus Control

From machine No.

W475N/S, W485N/S, W4105N/S, W4130N/S

W4180N/S

W4250N/S

W4330N/S

00521/402183-

00650/107384-

00725/105494-

00795/102510-

Thinking of you

 **Electrolux**

Contents

Contents

Safety Precautions	5
Technical data.....	7
Installation H-model	13
Transportation and unpacking, W465H, W475H, W4105H.....	13
Transportation and unpacking, W4130H-W4300H	14
Siting and floor	15
Mechanical installation	16
Installation S-model	17
Siting.....	17
Floor.....	17
Casting a plinth.....	18
Installation on an existing floor or foundation.....	20
Installation on vinyl floor coverings	21
Installation, ships, oil-rigs etc	22
Welding a foundation.....	23
Installing the machine.....	24
Water connections.....	25
Drain connection	27
Steam connection	28
Connection of external liquid supplies	29
Electrical installation.....	31
How to convert heating elements from 3AC to 1AC	40
Function checks.....	47

The manufacturer reserves the right to make changes to design and component specifications.

Safety Precautions



Safety Precautions



The machine is only intended for water-wash use.

Do not allow minors to use the machine.

Do not hose down the machine with water.

The machine's door lock must under no circumstances be bypassed.

If the machine develops a fault, this must be reported to the person in charge as soon as possible. This is important both for your safety and that of others.

The machine is not intended to be used by people (including minors) with reduced physical or mental capacity or lack of experience and knowledge. Such people must be instructed in the use of the machine by a person who has responsibility for their safety. Minors must be supervised to ensure that they do not play with the machine.



All external equipment which is connected to the machine must be CE/EMC-approved and connected using an approved shielded cable.



In order to prevent damage to the electronics (and other parts) that may occur as the result of condensation, the machine should be placed in room temperature for 24 hours before being used for the first time.

1	Electrical connection
2	Cold water
3	Hot water
4	Hard water
5	Steam connection
6	Drain
7	Liquid detergent supply
8	Control panel
9	Soap box
10	Door opening, W465H, W475H: \varnothing 310, W4105H: \varnothing 365, W4130H: \varnothing 395, W4180H, W4240H, W4300H: \varnothing 435

	A	B	C	D	E	F	G	H	I	K	L	M	N	O	P	R	S
W465H	720	690	1115	355	720	825	45	1030	220	1010	135	910	830	360	100	240	-
W475H	720	690	1115	355	720	825	45	1030	220	1010	135	910	830	360	100	240	-
W4105H	830	705	1300	365	740	945	45	1115	220	1095	135	995	910	415	100	295	-
W4130H	910	785	1325	435	825	1035	125	1245	215	1225	300	1125	-	-	100	305	455
W4180H	970	870	1410	470	945	1120	115	1330	230	1290	315	1205	370	410	100	335	485
W4240H	1020	915	1445	500	955	1155	100	1360	215	1320	300	1240	350	360	100	360	510
W4300H	1020	1060	1445	500	1135	1155	100	1360	215	1320	300	380	-	-	100	360	330

W465H, W475H, W4105H, W4130H

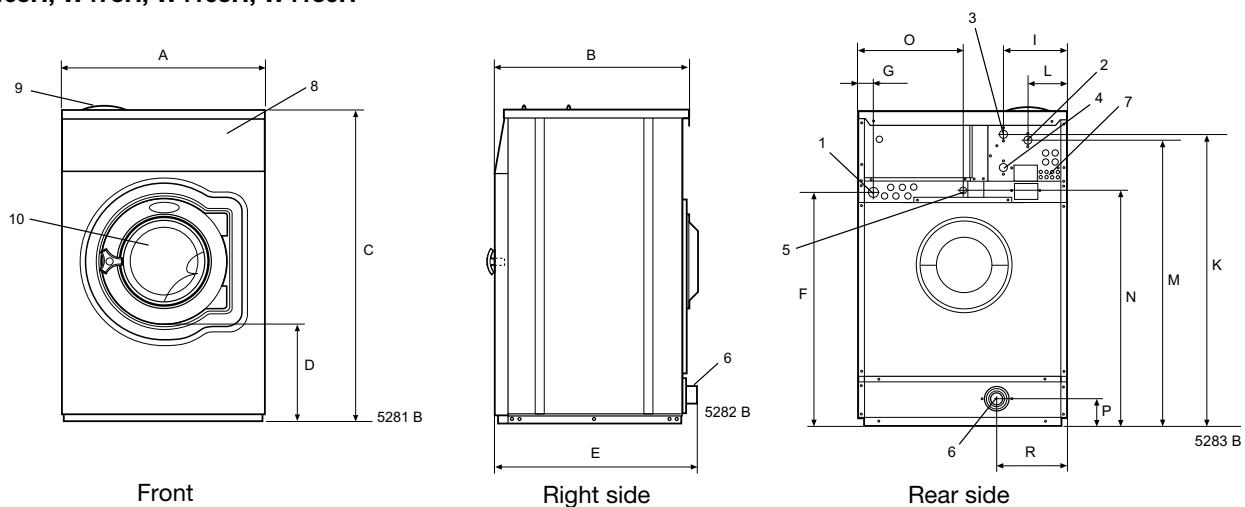

W4180H, W4240H, W4300H

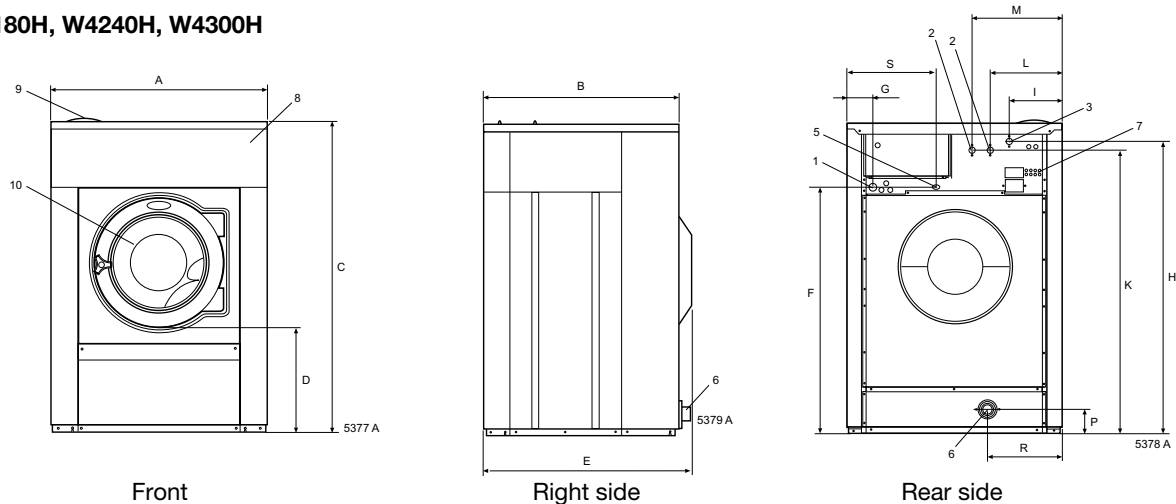

Technical data

1	Electrical connection
2	Cold water
3	Hot water
4	Steam connection
5	Drain
6	Liquid detergent supply
7	Control panel
8	Soap box
9	Water reuse
10	Door opening, W475S, W485S: $\varnothing 310$, W4105S, W4130S: $\varnothing 365$, W4180S: $\varnothing 395$, W4250S, W4330S: $\varnothing 435$

	A	B	C	D	E	F	G	H	I	K	L	M	N	O	P	R
W475S	660	690	1115	355	725	825	45	1030	215	1010	130	830	385	-	100	225
W485S	660	730	1115	355	765	825	45	1030	215	1010	130	830	385	-	100	225
W4105S	720	705	1200	365	740	910	45	1115	215	1095	130	910	420	-	100	235
W4130S	720	790	1200	365	825	910	45	1115	215	1095	130	910	420	-	100	235
W4180S	750	880	1325	435	915	1035	45	1245	130	1225	215	1040	325	295	100	225
W4250S	830	955	1410	470	990	1120	45	1330	160	1290	245	1125	325	325	100	265
W4330S	910	1040	1445	500	1075	1155	45	1365	160	1325	245	1155	280	325	100	210

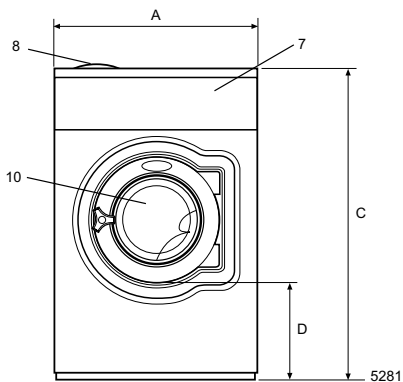

Front

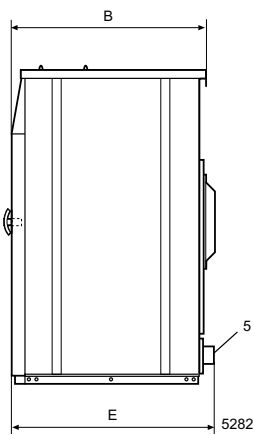

Right side

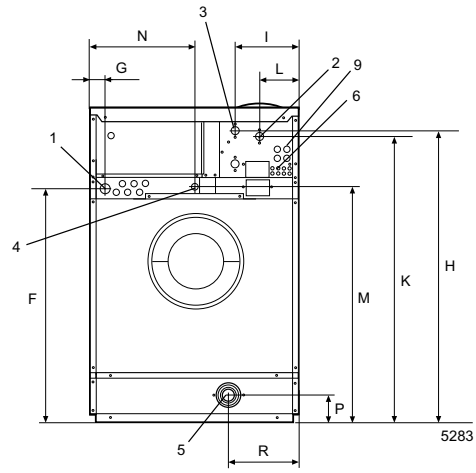

Rear side **W475S-W4130S**

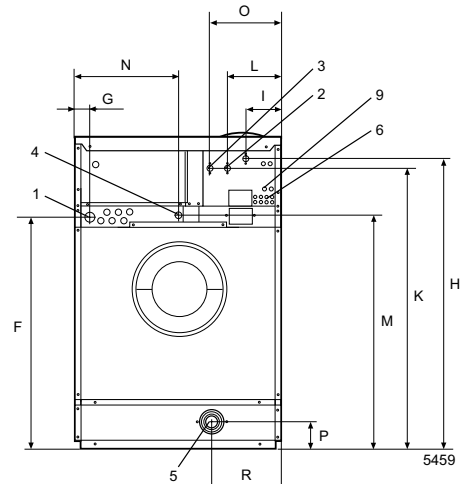

Rear side **W4180S-W4330S**

	W465H	W475H	W4105H	W4130H	W4180H	W4240H	W4300H
Frequency of the dynamic force Hz	18.3	18.3	17.1	16.3	15.5	14.8	13.7
Max floor load at extraction kN	1.8±0.5	1.9±0.5	2.5±0.5	3.1±0.5	4.2±1.0	5.2±1.0	6.2±1.2

	W475S	W485S	W4105S	W4130S	W4180S	W4250S	W4330S
Frequency of the dynamic force Hz	9.3	11.6	10.8	10.8	10.3	9.8	9.4
Max floor load at extraction kN	1.1±2.8	1.7±3.3	2.1±4.0	2.3±4.7	2.7±5.9	3.7±7.4	4.2±8.8

Installation H-model

Transportation and unpacking, W465H, W475H, W4105H

The machine is delivered complete with expansion bolts etc. packed inside the machine in the drum.

The machine is delivered bolted onto the transport pallet and packed in a crate or box.

- Remove packing from the machine.
- Remove front panel. Remove the bolts between the machine and pallet.
- Mount front panel.

When the machine is lifted off the pallet: Make sure that the machine does not come down on the floor with either of the rear corners first. The side panel of the machine can be damaged.

- Mount the feet.
- Place the machine on its final position.
- Level the machine with the feet of the machine.

①

② The machine also comes with transport safety devices (four plate angles between the support and the drum).

In order to remove the safety devices:

- Remove front and rear panel.
- Remove both front metal angels.
- Remove both rear metal angels.
- The machine may not be moved with the transport securities removed. Save the transport securities for future use.

③

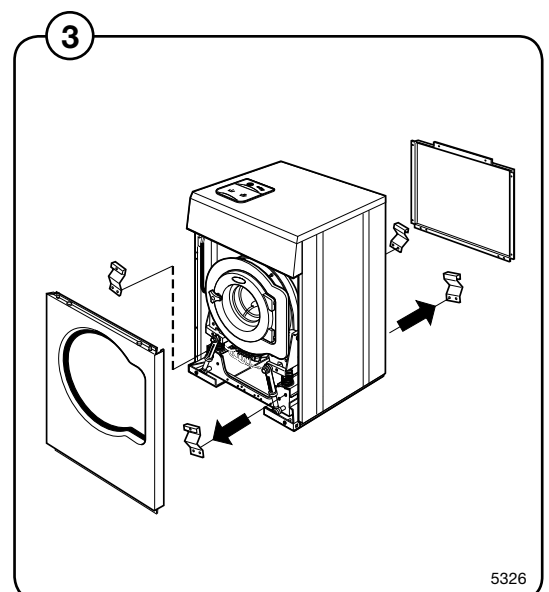
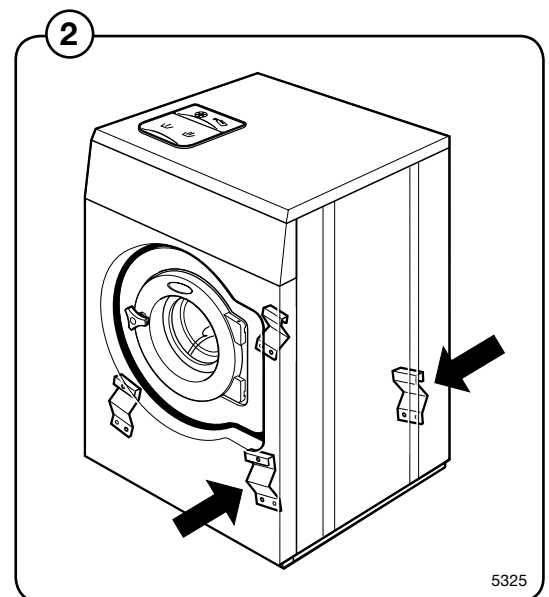
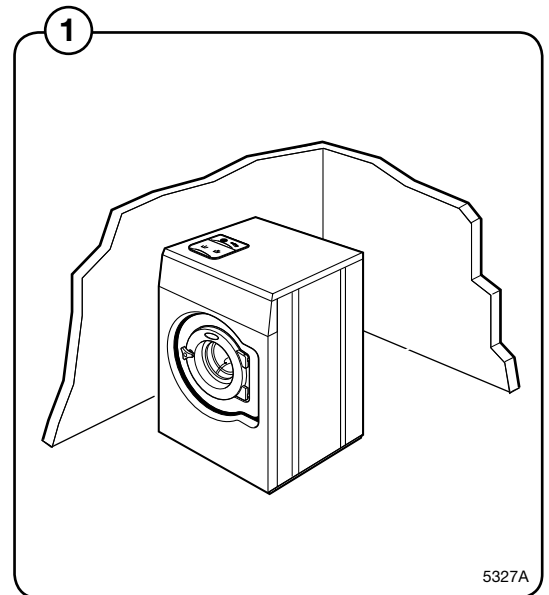

Transportation and unpacking, W4130H, W4180H, W4240H, W4300H

The machine is delivered complete with expansion bolts etc. packed inside the machine in the drum.

The machine is delivered bolted onto the transport pallet and packed in a crate or box.

- Remove packing from the machine.
- Remove front and rear panel. Remove the bolts between the machine and pallet.
- Mount front and rear panel.
- Mount the feet.

NOTE!

⑤ Regarding W4300H note the positioning of the two front feet.

- ①
- Place the machine on its final position.
 - Level the machine with the feet of the machine.

④ The machine also comes with transport safety devices (two plate angles between the support and the drum).

In order to remove the safety devices:

- ⑥
- Remove the two side panels.
 - Remove the two transport securities.
 - The machine may not be moved with the transport securities removed. Save the transport securities for future use.

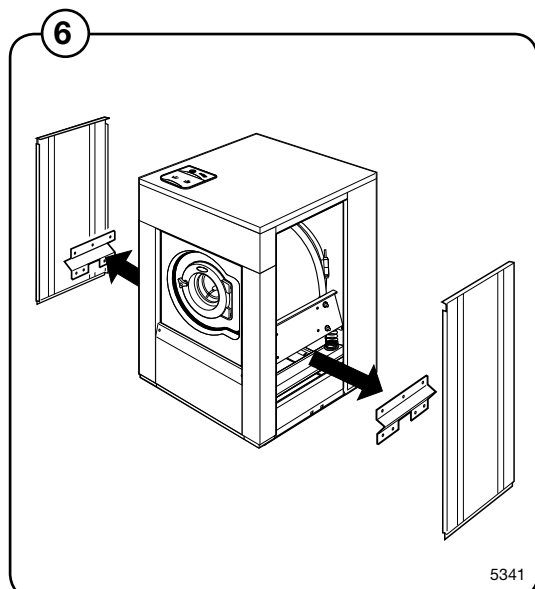
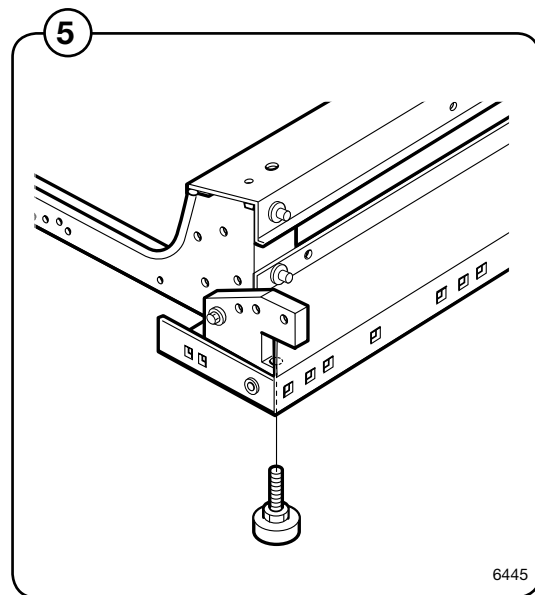
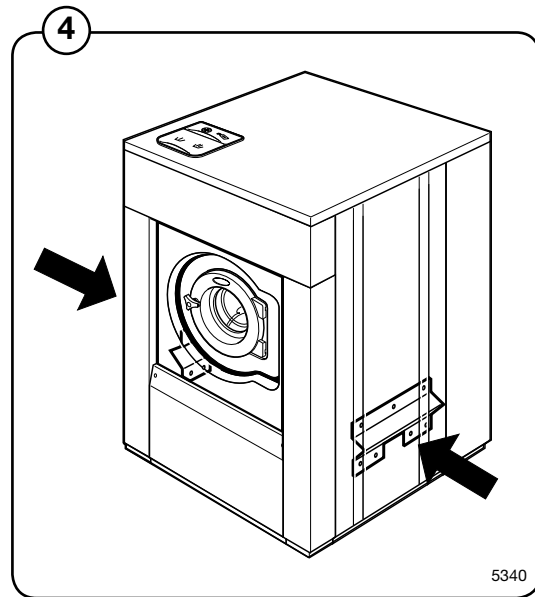

Siting and floor

Install the machine close to a floor drain or open drain.

- 7 In order to make installation and servicing the machine easier the following clearances are recommended:
- At least 500 mm between the machine and the wall behind
 - and min. 50 mm on both sides of the machine whether installed next to the wall or other machines.

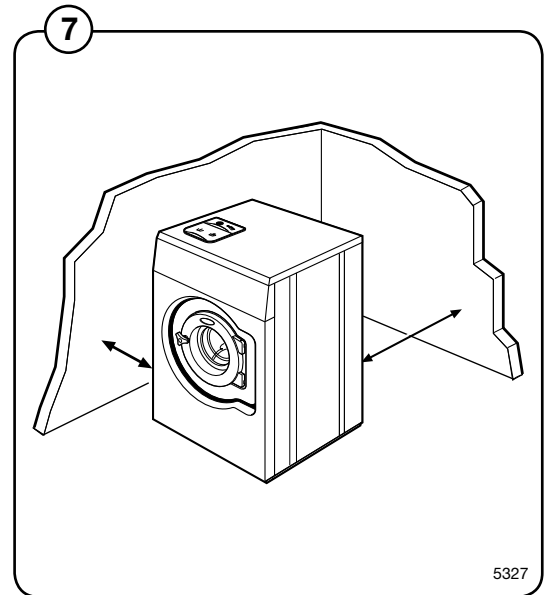

Mechanical installation

- 8 • Mark and drill 2 holes (\varnothing 8 mm) about 40 mm deep (W465-W4105) and \varnothing 10 mm and 50 mm deep (W4130-W4240) in the positions shown.

	A	B	C	D	E	F	G	H
W465H	495	460	110	130	375	170	40	100
W475H	495	460	110	130	375	170	40	100
W4105H	575	465	130	140	455	185	35	95
W4130H	635	490	135	175	515	195	60	110
W4180H	715	545	125	205	595	185	60	115
W4240H	790	615	115	180	670	175	60	115
W4300H	810	840	60	180	670	175	60	75

● = position of feet

○ = drilling points for expander bolts

- The machine shall be lifted in the bottom frame.
- Place the machine over the two drilled holes.
- Check that the machine is placed in level. Adjust with the feet.



It is of utmost importance that the machine is placed in level, from side to side as well as front to rear. If the machine is not properly leveled, it may result in out-of-balance without a real out of balance in the drum.

- Insert the expansion bolts supplied in the holes drilled in the floor. Fit the washers and nuts, and tighten well.

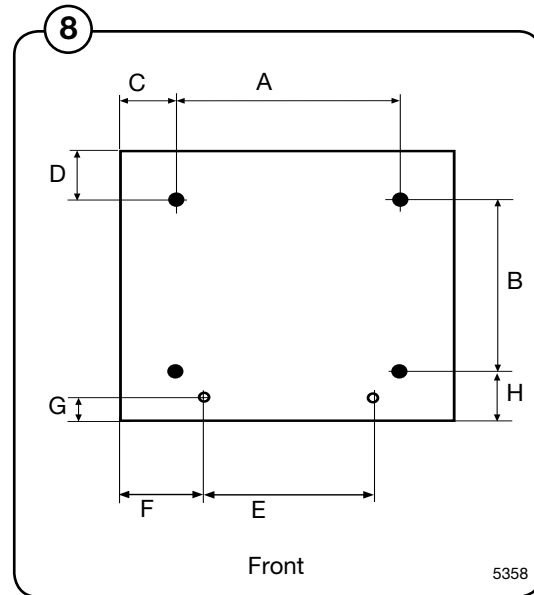

Installation S-model

Leave the machine on the transport pallet until it can be placed in the final, prepared position.

Siting

Install the machine close to a floor drain or open drain. In order to make installation and servicing the machine easier the following clearances are recommended:

- ⑨ • At least 500 mm between the machine and the wall behind.
- Minimum 25 mm to next machine if more than one machine are installed on a foundation.

Floor

In this type of machine, the drum is attached directly to the frame. As a result the floor under the machine must be stable enough to absorb the dynamic forces generated during spin cycles. For that reason, the mounting bolts must be cast into the floor material itself.

When fixing the machine to an existing cement floor, it must be and at least 100 mm thick.

The floor must be able to withstand the loads indicated in the table.

If it isn't possible to cast the bolts into the floor, an alternative might be to use so-called chemical anchors. Your local dealer can provide the information you need.

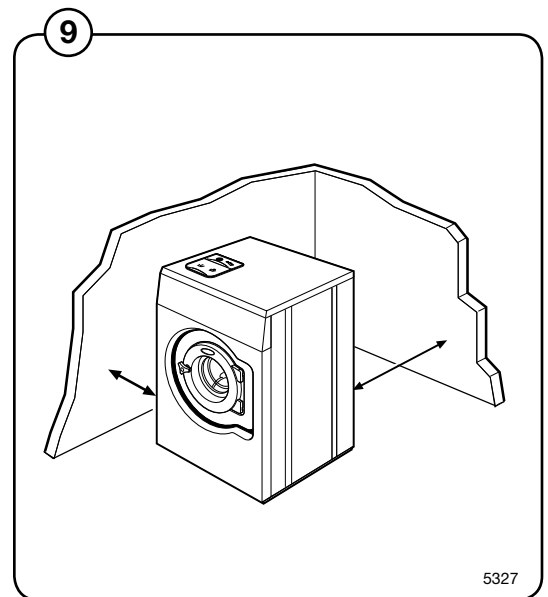

Casting a plinth

- 10 A plinth should be used where the existing floor is less than 100 mm thick or in order to ensure that the machine is above the level of any water leakages.

The plinth should be approximately 150 - 200 mm in height.

Proceed as follows:

- 11
- Break up the existing floor to a depth of approx. 75 mm and check that the sides of the hole are tapered outward so that the longest side at the bottom measures 120 mm more than at the top.
 - Make the mould for the plinth.
 - Moisten the hole well and apply cement to the sides and bottom.
- 12
- 4 bolts must be set into the concrete of the machine base. The bolts need to project 40 mm out of the base. Pour the concrete into the prepared base mould and make sure that the surface is level.
 - The concrete should be left to set for at least two days before mounting the machine on the plinth.

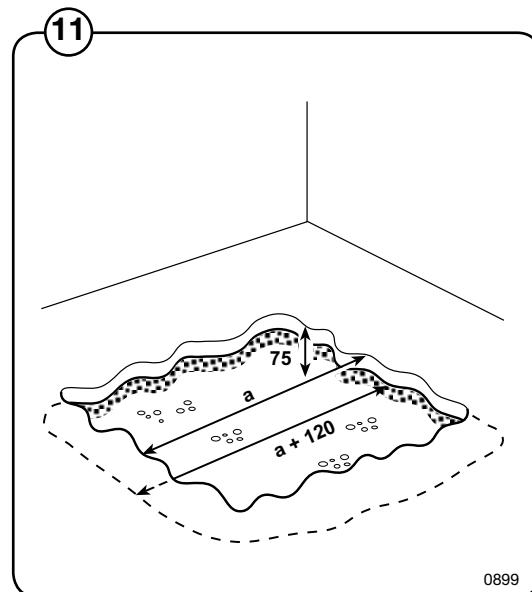
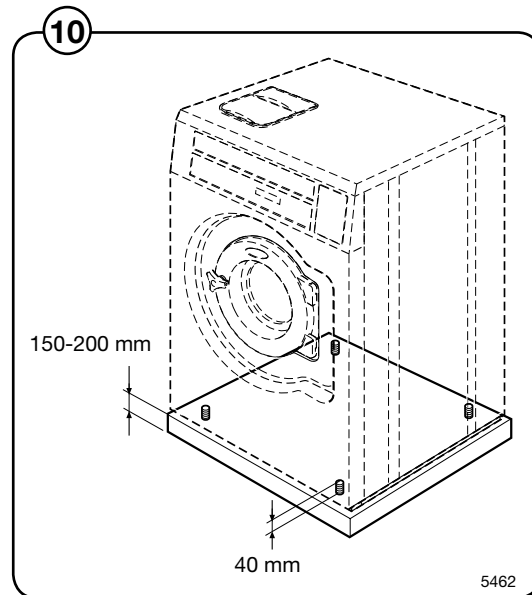

For these machines two expander bolts shall be mounted at the front part of the machine.

- Drill two holes (1) $\varnothing 10$ mm and 40 mm deep.
- After the machine has been placed over the other four bolts, place the two spacer washers over the two holes. They shall be placed between the machine and foundation.
- Mount the expanderbolts in the drilled holes and fasten the machine. Don't forget the washers.

	A	B	C	D	E	F	G	H	I
W475S	685	660	495	395	115	635	-	-	-
W485S	725	660	495	445	115	665	495	0	75
W4105S	700	720	575	385	120	695	595	10	80
W4130S	785	720	575	495	120	760	595	10	80
W4180S	875	750	635	570	120	855	655	10	85
W4250S	950	830	715	635	125	955	735	10	85
W4330S	1035	910	790	695	135	1050	810	10	95

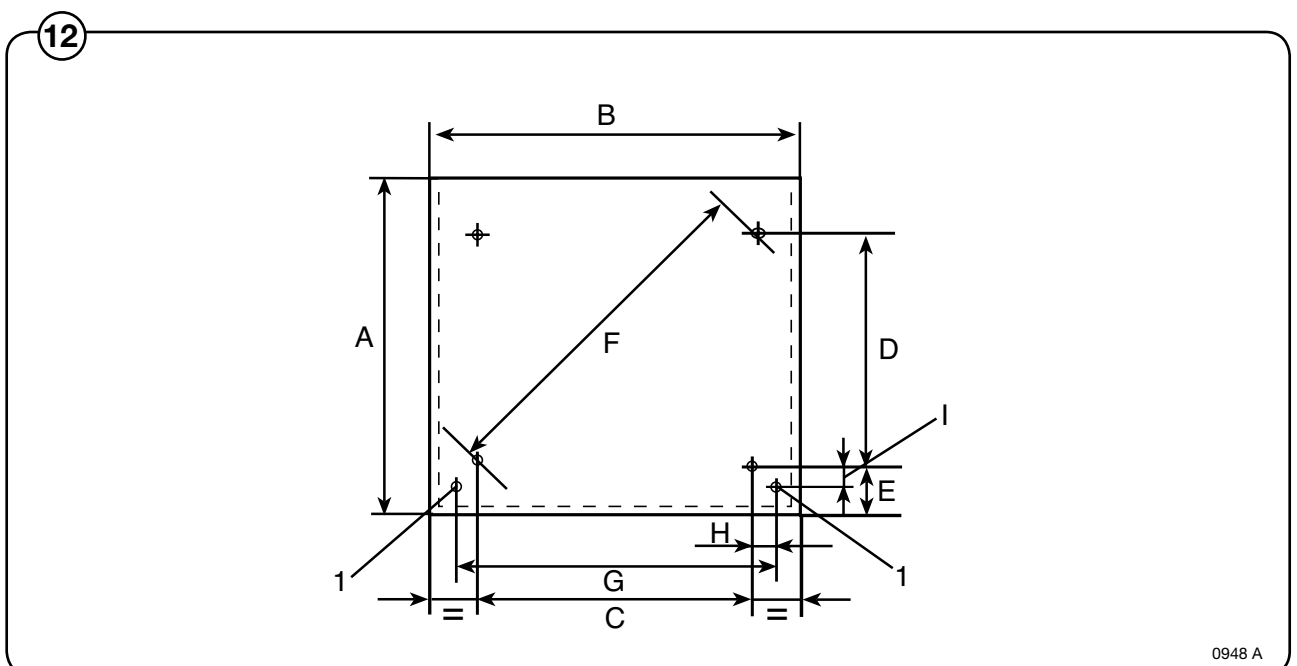

Installation on an existing floor or foundation

Instead of bracing up the existing floor or foundation, chemical bolts M16 can be used. A set of four HILTI HVU bolts can be ordered from our Spares Dept, part No. 471 6699-64.

Mounting instruction

- 13 • Drill \varnothing 18 mm (11/16") to a depth of 125 mm (5"). Do not make the hole too deep.
- 14 • Clean the drilled holes.
- 15 • Put down the chemical ampule in the hole.
- 16 • Rotate the bolt into the hole, so that the glass ampule is broken and its contents mixed.
- 17 • Rotate the bolt to correct depth.
NOTE! Do not rotate the bolt against the concrete bottom. Check that the chemicals have filled the hole completely.
- 18 • Remove the drilling machine with the mounting tool. Hold the bolt with one hand. Let the bolt harden before the machine is mounted.

Time for hardening, due to different concrete temperatures.

- 10°C	6 hours
- 5°C	2.5 hours
± 0°C	1 hour
5°C	30 minutes
10°C	20 minutes
15°C	15 minutes
20°C	10 minutes

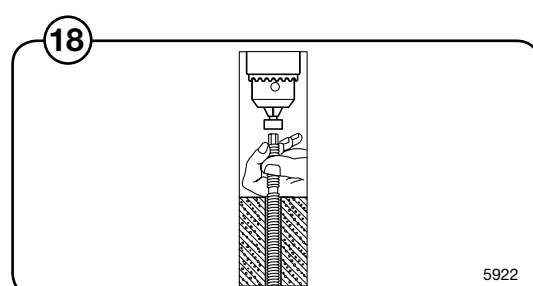
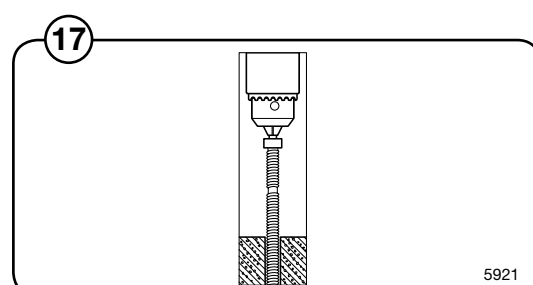
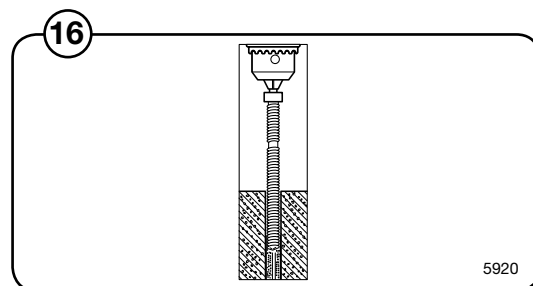
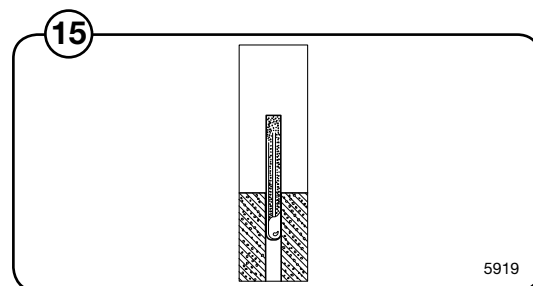
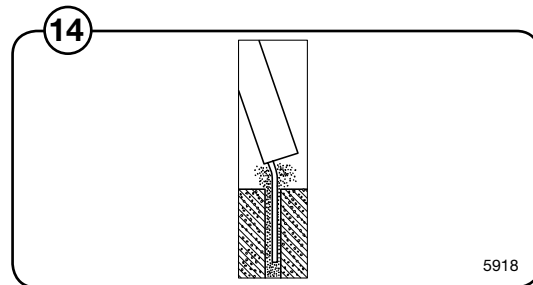
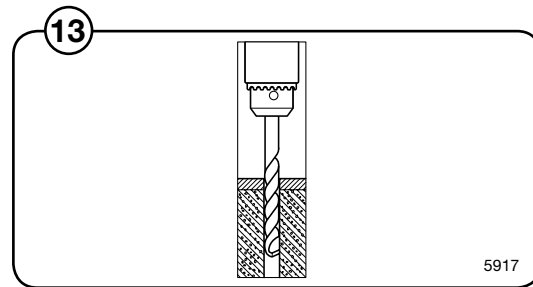

Installation on vinyl floor coverings

- 19 If chemical anchors are to be used, drill holes for the mounting points.
 - 20 Cut the flooring material around the washers (washers and sealant are supplied in installation kit).
 - 21 Apply sealant to the hole cut in the vinyl floor covering. Insert the washer. Use sealant to seal around the washer between the vinyl and the washer.
 - 22 Put the machine into place. Check that the machine is level. If it is not, use spacers where required between floor and machine.
- If chemical anchors are used, do not use the nut and washer supplied with them.
- Fix the machine in place using the washers and nuts supplied with the machine.
- 23 Installation with mounting frame.

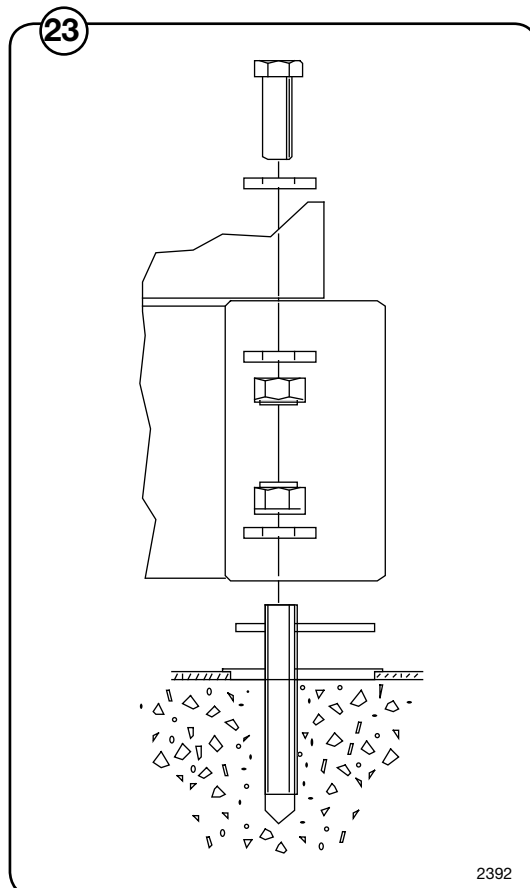
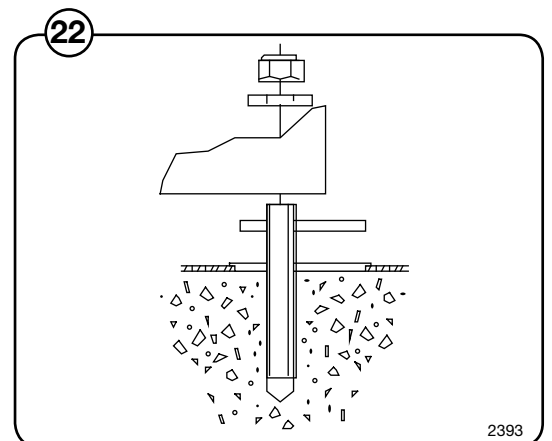
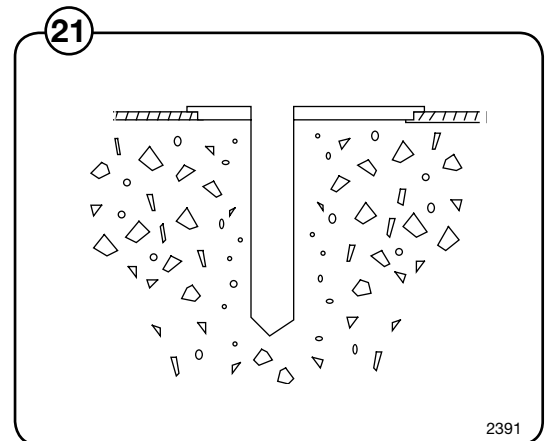
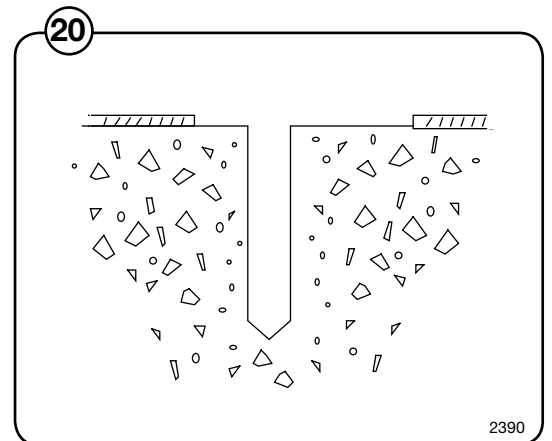
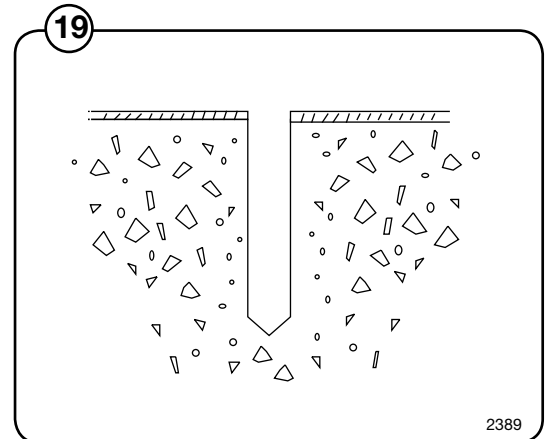

Installation, ships, oil-rigs, etc

Leave the machine on the transport pallet until it can be placed in the final, prepared position.

Siting

Install the machine close to a deck drain or open drain. In order to make installation and servicing the machine easier the following clearances are recommended:

Floor

In this type of machine, the drum is attached directly to the frame. As a result the deck under the machine must be stable enough to absorb the dynamic forces generated during spin cycles.

The combination deck and foundation must be able to withstand the loads indicated in the table.

Some marine installations have very thin decks. Special attention to be taken. Reinforcing deck plus increased size of foundation may be necessary.

Welding a foundation

- 24 A welded foundation shall be made where concrete foundation can not be made.

In order to make installation and servicing the machine easier the following clearances are recommended:

- At least 1000 mm between the machine and the wall behind.

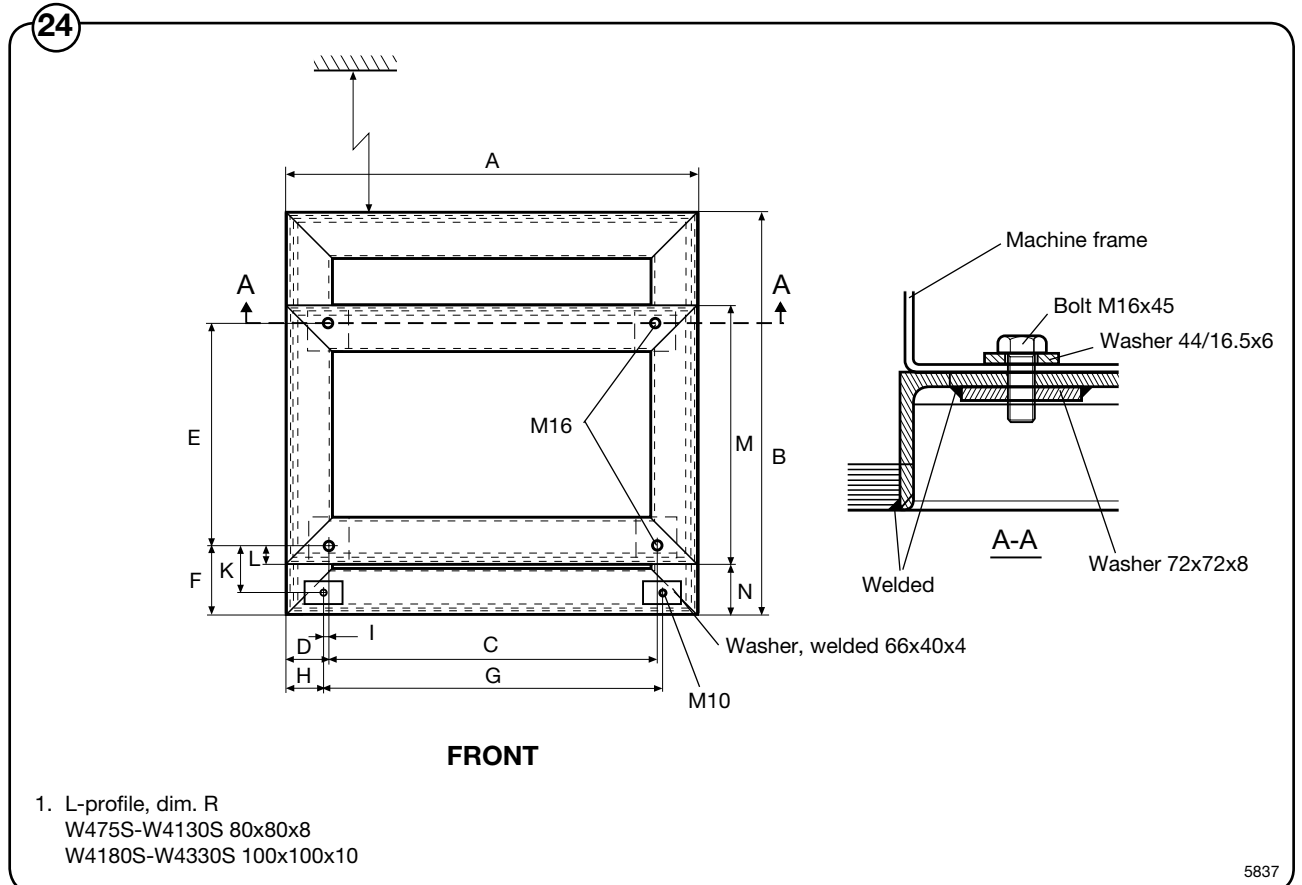

	A	B	C	D	E	F	G	H	I	K	L	M	N
W475S	660	685	495	80	395	115	-	-	0	-	30	455	85
W485S	660	725	495	80	445	115	495	80	0	75	30	505	85
W4105S	720	700	575	75	385	120	595	65	10	80	30	445	85
W4130S	720	785	575	75	495	120	595	65	10	80	30	555	85
W4180S	750	875	635	55	570	120	655	45	10	85	30	630	90
W4250S	830	950	715	55	635	125	740	45	10	85	30	695	95
W4330S	910	1035	790	60	695	135	810	50	10	95	30	755	105

Installing the machine

To install the machine:

- Remove the transport packaging
- Remove the front panel.
- Remove the machine from the transport pallet and locate it on the bolts. When the machine is lifted off the pallet: Make sure that the machine does not come down on the floor with either of the rear corners first. The side panel of the machine can be damaged. Always lift the machine by the chassis, never by the door or door handle.
- 25 • Check that the machine is level and steady in all four corners mounting points. Adjust the level by using stainless or galvanized steel washers between the machine and the floor. The washers must be of a size to cover the support surface.
- 26 • Fit the washers and self-locking nuts supplied with the machine and tighten well.
- 27 • To tighten the nuts we recommend to use a ratchet wrench, especially in the right rear corner.

After the machine has been in use for a while, check and re-tighten the nuts if necessary.

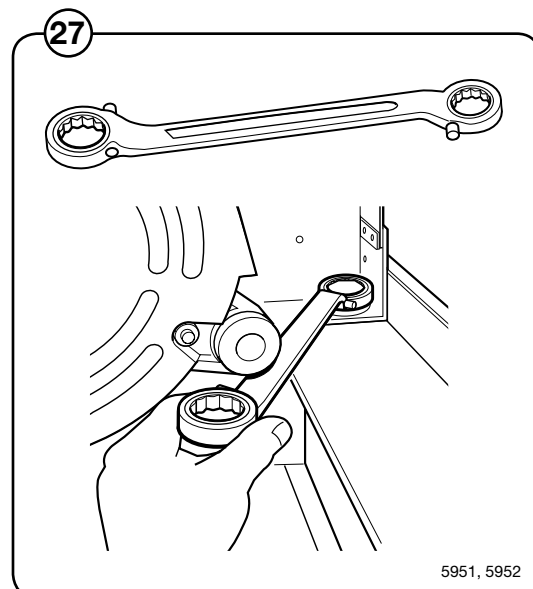
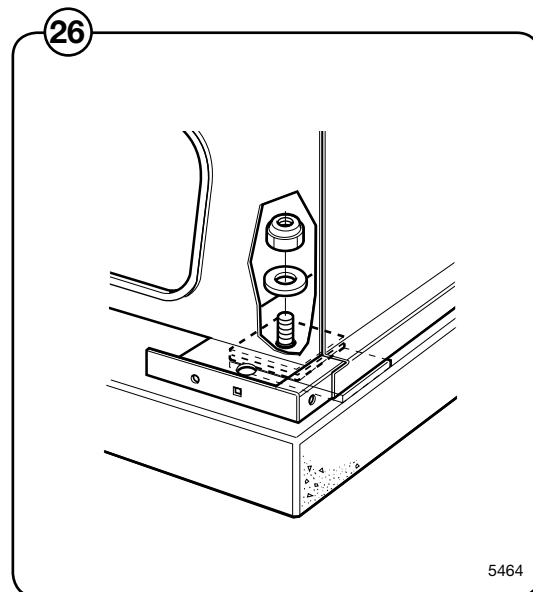
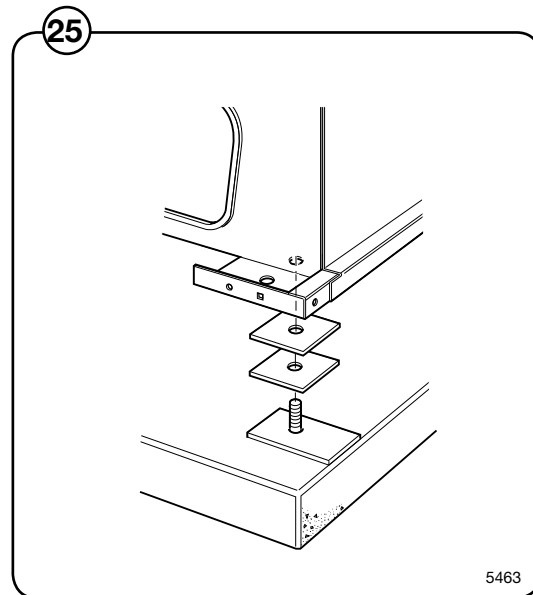

Water connections

All intake connections to the machine are to be fitted with manual shut-off valves and filters, to facilitate installation and servicing.

Water pipes and hoses should be flushed clean before installation. After installation hoses should hang in gentle arcs.

All connectors present on the machine must be connected up. The table shows the possible connection options, which will depend on the water types to be connected to the machine. Check the machine plates too.

All water connectors must be connected up, otherwise the wash program will not function correctly.

Hoses are to be of an approved type and grade and comply with IEC 61770.

Machines shall be connected with new water hoses. Re-used water hoses must not be used.

The water pressure data is as follows:

- min: 50 kPa (0,4 kp/cm²)
- max: 1 MPa (10 kp/cm²)
- recommended: 200-600 kPa (2-6 kp/cm²)



If the water pressure is below the min. value, the wash result can not be guaranteed for certain program.

Installation

	Water type	Water connection			
		1	2	3	4
28	cold	cold			**
29	cold and hot	cold	hot		**
30	cold and hot	cold	hot	cold/ hot*	**

* For detergent container.

** Extra water valve which can be used for hard water if soft water is connected to 1.

This valve can also be used for water reuse from tank.

If pump is used, it is only a water connection without valve.

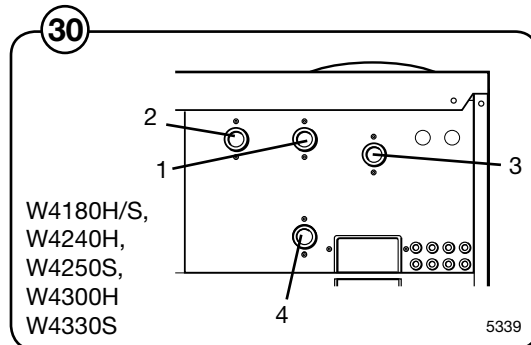
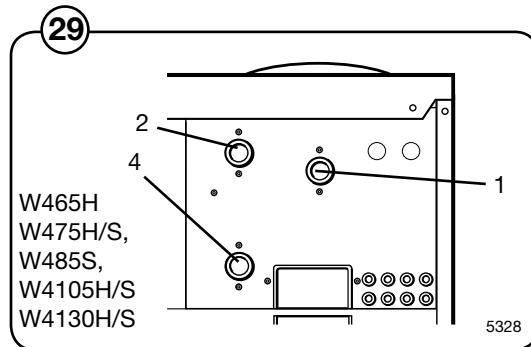
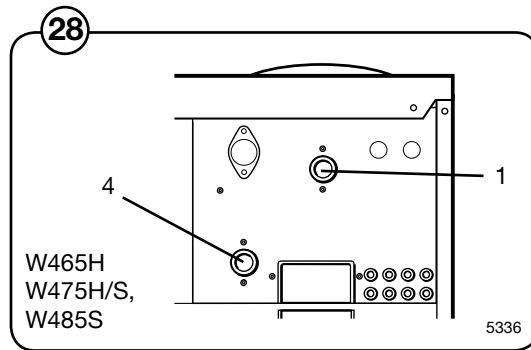

Drain connection

Connect a 75 mm (3") (alt. 50 mm, 2" and only W465-W4105) pipe or rubber hose to the machine's drain pipe, ensuring a downward flow from the machine. Avoid sharp bends which may prevent proper draining.

- 31 The drainage pipe should be located over a floor drain, drainage channel or the like so that the distance between the outlet and the drain is at least 25 mm (1").

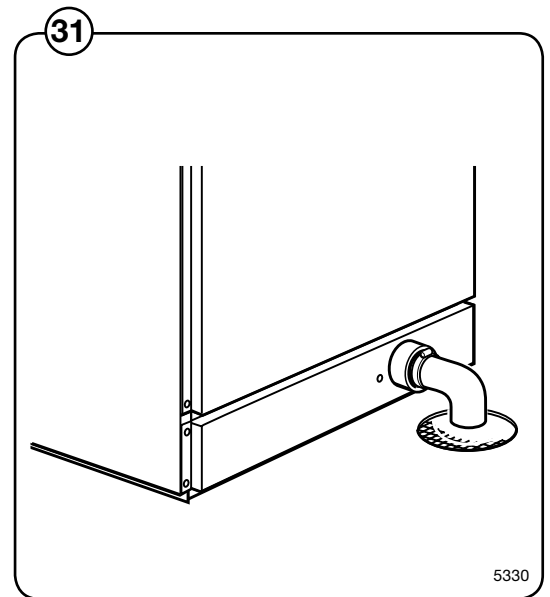

5330

Steam connection

The steam supply to the machine should be fitted with manual shut-off valves and filters to facilitate installation and servicing.

The connection hose must be of type ISO/1307-1983 or equivalent. Connection size at filter: DN 15 (BSP 1/2").



Steam pressure required:

- minimum: 50 kPa (0.5 kp/cm²)
- maximum: 800 kPa (8 kp/cm²)

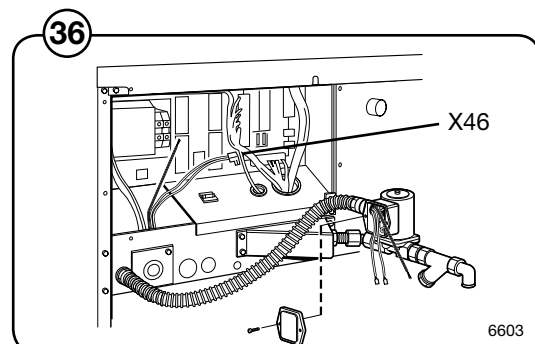
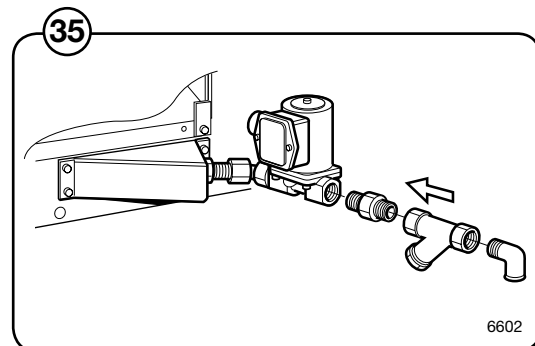
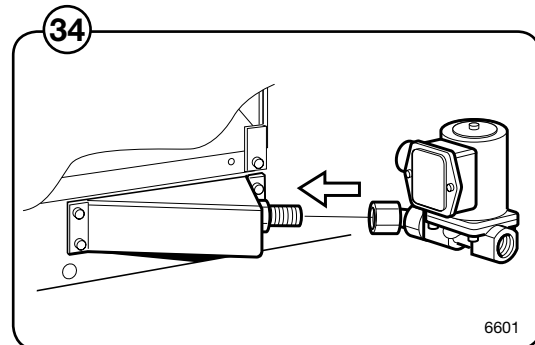
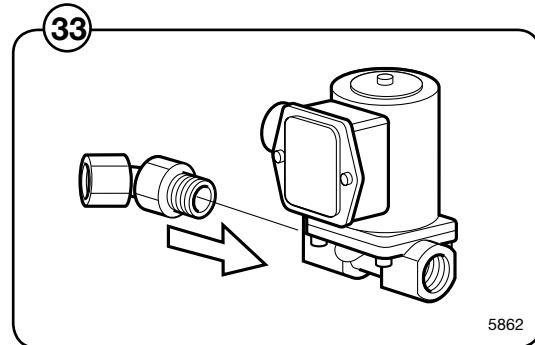
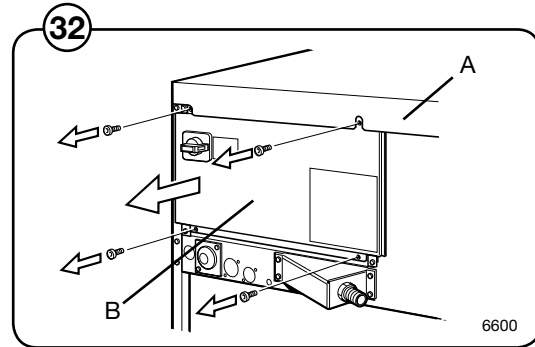
- 32 • Remove the cover (A).
- 33 • Mount the articulated nipple to the steam valve.
- 34 • Mount the steam valve on the machine.
- 35 • Mount nipple, strainer and elbow. Note the direction of the strainer. Mount steam hose to the elbow. Check that there are no sharp angles or bends on the connected steam hose.
- 36 • Mount the hose with wires between steam valve and machine. Connect wires in the steam valve. Connect ground cable to the terminal ground connection. Mount the cable connector on X46 on distribution card.



Connection of external liquid supplies

 
Electrical installation must be carried out by an authorized personnel!

 
All optional equipment connected must be EMC-approved to EN 50081-1 or EN 50082-2.

37 Distribution card A can be used to control external functions, output and input signals.

38 **Outputs (110-240V AC):**

- X71:1,2 Signal "Door locked, program on"
- X72:1 0 V (common)
- X72:2 Liquid supply 1
- X72:3 Liquid supply 2
- X72:4 Liquid supply 3
- X72:5 Liquid supply 4
- X73:1 Detergent box 1 (Y11)
- X73:2 Detergent box 2 (Y12)
- X73:3 Detergent box 3 (Y13)
- X73:4 Detergent box 4 (Y14)
- X73:5 Detergent box 2 (Y22)

Inputs:

- X70:1,2 Paus/PC5
- X70:3,4 Start/Stop

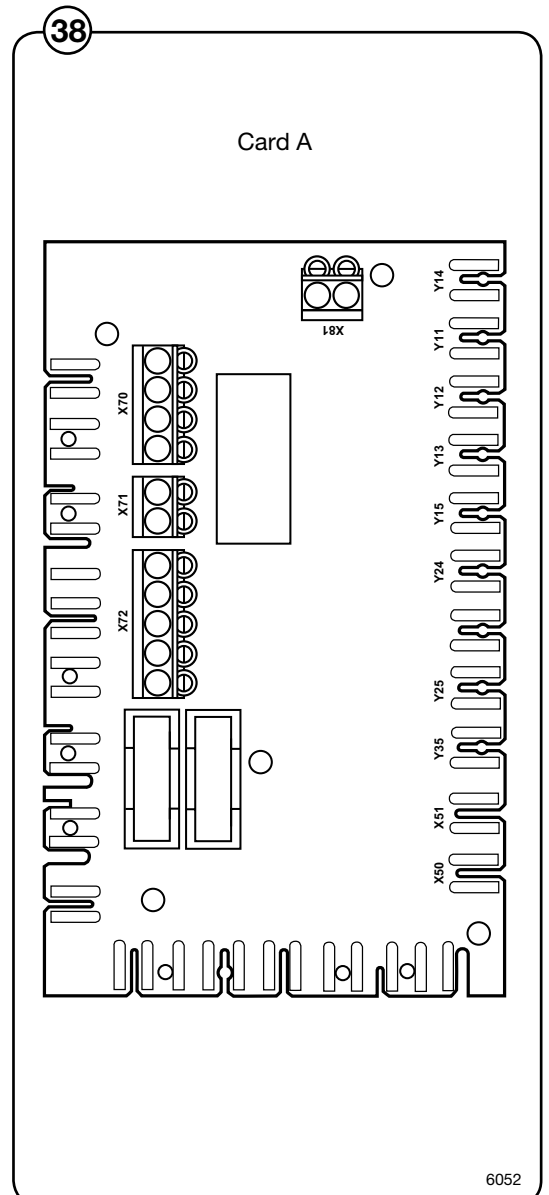
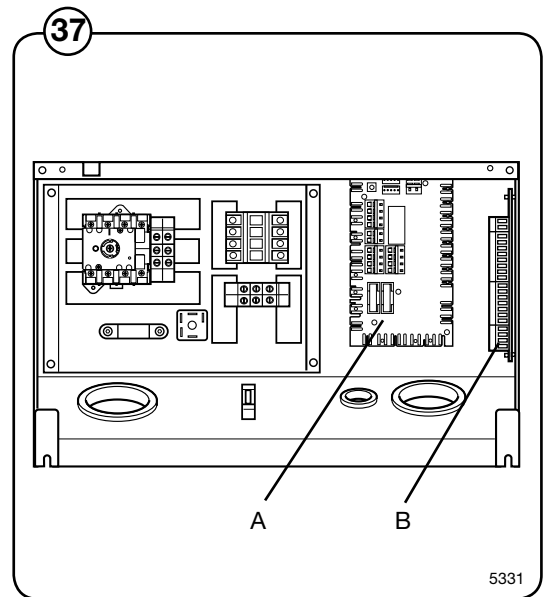

- 39 If more signals are required the machine can be equipped with a second distribution card B.

Outputs (200-240V AC):



- X75:1 0 V (common)
- X75:2 Liquid supply 5
- X75:3 Liquid supply 6
- X75:4 Liquid supply 7
- X75:5 Liquid supply 8
- X76:1 0 V (common)
- X76:2 Drain lock
- X76:3 Drain A
- X76:4 Drain B
- X76:5 Drain C
- X76:6 Inlet A
- X76:7 Inlet B
- X76:8 Inlet C
- X77:1 Buzzer (N)
- X77:2 Buzzer (L1)

Inputs:

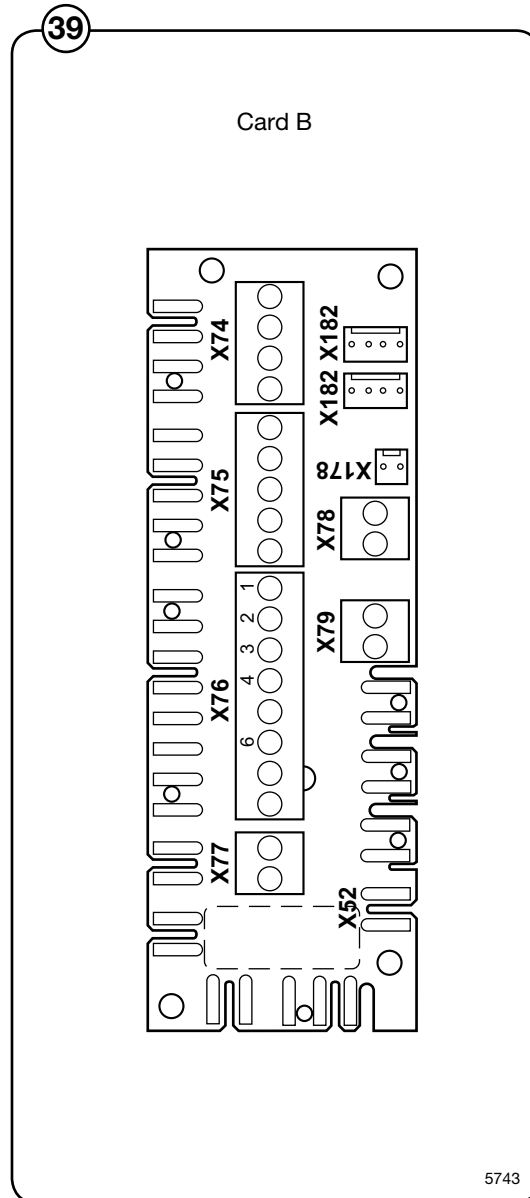

- X74:1,2 Switch between heating 1/heating 2
- X74:3,4 No function



Electrical installation

Electrical installation must be carried out by an authorized personnel!

Machines with frequency-controlled motors can be incompatible with certain types of earth leakage circuit breaker. It is important to know that the machines are designed to provide a high level of personal safety, which is why items of external equipment such as earth leakage circuit breakers are not necessary. If you still want to connect your machine across an earth leakage circuit breaker, please remember the following:

- **contact a skilled, authorised installation company to ensure that the appropriate type of breaker is chosen and that the dimensioning is correct**
- **for maximum reliability, connect only one machine per earth leakage circuit breaker**
- **it is important that the earth wire is properly connected, including to the earth leakage circuit breaker.**

Mount a multi-pole switch prior to the machine to facilitate installation and service operations.

The connecting cable should hang in a gentle curve.

Fuse size, see table.

Single-phase connection:

- ④ Connect the earth and other two wires as shown in example in the figure.

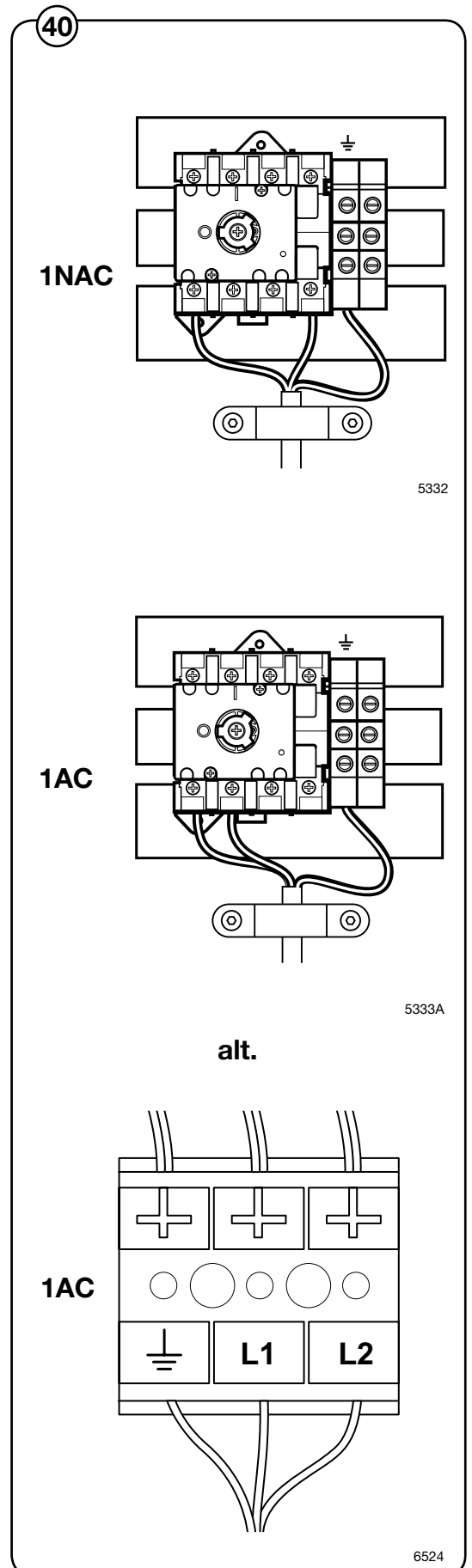

Three-phase connection:

- ④1 Connect the earth, neutral and phase wires as shown in example "3AC" and "3N AC" in the figure.

When the installation is completed, check:

- that the drum is empty.
- that the machine operates by turning on the mains switch, starting the machine and using RAPID ADVANCE to reach the spin cycle (see operations manual).

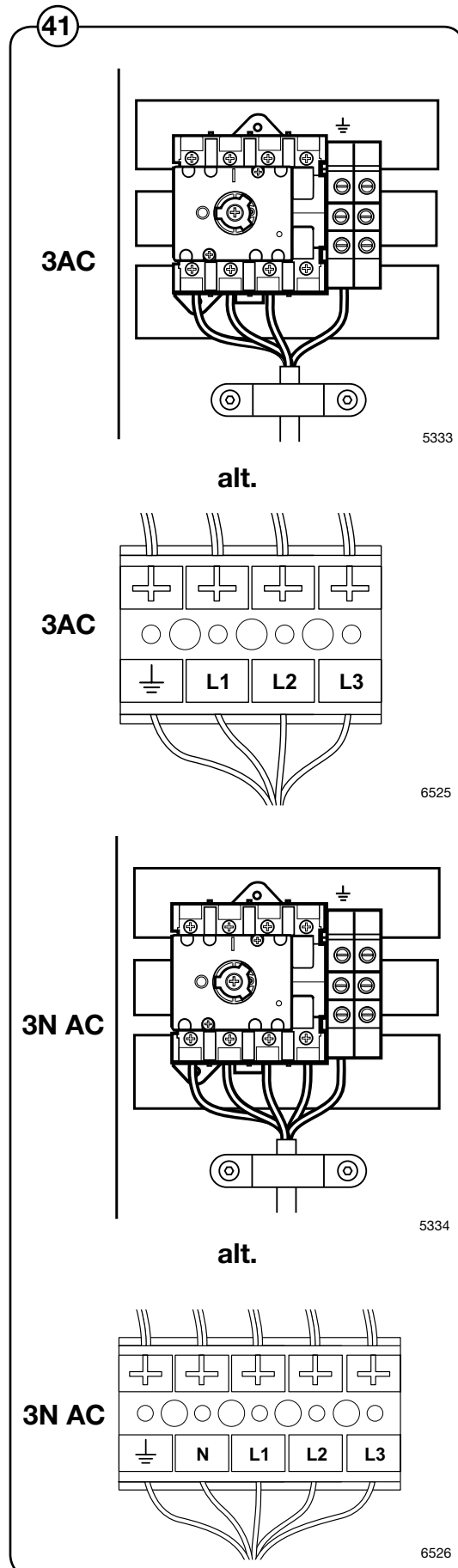

42

**IMPORTANT**

415V 3AC machines can be supplied with 380, 400 or 415V.

240V 1AC machines can be supplied with 220, 230 or 240V.

In the machine there is a transformer placed in the front control unit (under the top cover). This transformer is preset for 240V which is applicable for machines intended for 240V 1- or 3AC and 415V 3AC.

If your supply voltage is 220 or 230V, 1- or 3AC or 380 or 400V 3AC the jumper on the transformer has to be moved to 230V-COM instead of COM-240V.

If the jumper is not moved in the above described cases there is a risk that the machine will not work in installation sites with undervoltage.

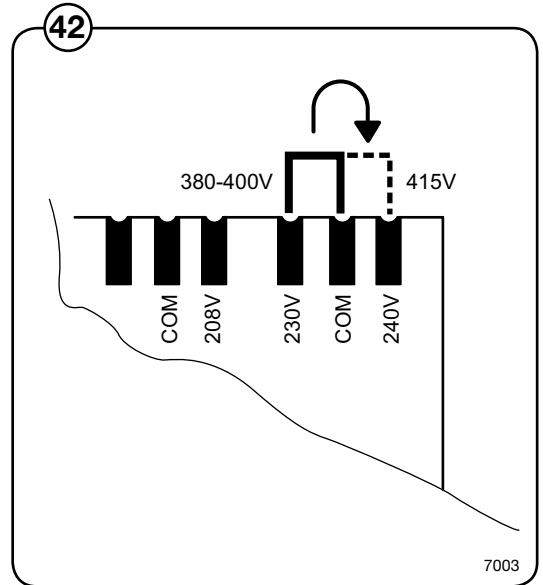

W465H

Heating alternative	Voltage alternative	Total kW	Fuse A
No heating or Steam heating	200 V 3 AC	1	10
	208-240 V 1 AC	1	10
EI heating	200 V 3 AC	5.6	20
	220-240 V 1 AC	2.2	16
	220-240 V 1 AC	3.2	16
	230/240 V 1 AC	4.4	20
	220-240 V 1 AC	7.3	35
	220-240 V 3 AC	3.2	10
	220-240 V 3 AC	7.3	20
	240 V 1 AC	5.4	25
	230/240 V 3 AC	4.4	16
	230/240 V 3 AC	5.8	16
	380-415 V 3/3N AC	3.2	10
	400/415 V 3/3N AC	4.4	10
	380/400/415 V 3/3N AC	5.8	10
	380-415 V 3/3N AC	7.3	16
	440/480 V 3 AC	7.9	16
	380-415/220-240 V 3/3N AC	7.3	16/20
	415/240 V 3N/3/1 AC	7.9/5.4	16/25

W475H

Heating alternative	Voltage alternative	Total kW	Fuse A
No heating or Steam heating	100-120 V 1 AC	1.1	16
	200 V 3 AC	1.1	10
	208-240 V 1 AC	1.1	10
EI heating	200 V 3 AC	5.6	20
	220-240 V 1 AC	2.3	16
	220-240 V 1 AC	3.2	16
	230/240 V 1 AC	4.4	20
	240 V 1 AC	5.4	25
	220-240 V 1 AC	5.4	25
	220-240 V 1 AC	7.4	35
	220-240 V 3 AC	3.2	10
	230/240 V 3 AC	4.4	16
	220-240 V 3 AC	5.4	16
	220-230 V 3 AC	7.0	20
	220-240 V 3 AC	7.4	25
	380-415 V 3/3N AC	3.2	10
	400/415 V 3/3N AC	4.4	10
	380-415 V 3/3N AC	5.4	10
	380-415 V 3/3N AC	7.4	16
	440/480 V 3 AC	7.9	16
	380-415/220-240 V 3/3N AC	7.4	16/25
	415/240 V 3/3N/1 AC	7.9/5.4	16/25

W4105H

Heating alternative	Voltage alternative	Total kW	Fuse A
No heating or Steam heating	200 V 3 AC	1.3	10
	208-240 V 1 AC	1.3	10
EI heating	200 V 3 AC	5.6	20
	220-240 V 3 AC	3.2	16
	240 V 1 AC	7	35
	220-240 V 1 AC	7.4	35
	220-240 V 1 AC	9.7	50
	220-240 V 3 AC	3.2	10
	220-240 V 3 AC	7.4	25
	208-240 V 3 AC	9.2	35
	220-240 V 3 AC	9.7	35
	380-415 V 3/3N AC	3.2	10
	380-415 V 3/3N AC	7.4	16
	380-415 V 3/3N AC	9.7	16
	440/480 V 3 AC	7.9	16
	440/480 V 3 AC	10.5	16
	380-415/220-240 V 3/3N AC	7.4	16/25
	380-415/220-240 V 3/3N AC	9.7	16/35
	415/240 V 3/3N AC	7.9/5.5	16/25
	415/240 V 3/3N AC	10.5/5.7	16/35

W4130H

Heating alternative	Voltage alternative	Total kW	Fuse A
No heating or Steam heating	200 V 3 AC	1.3	10
	208-240 V 1 AC	1.6	10
EI heating	200 V 3 AC	9.5	35
	220-240 V 1 AC	12.5	63
	208-240 V 3 AC	11.8	35
	220-240 V 3 AC	12.5	35
	380-415 V 3N/3 AC	12.5	20
	415 V 3N AC	12.5	25
	440/480 V 3 AC	13.5	20
	380-415/220-240 V 3N/3	12.5	20/35

W4180H

Heating alternative	Voltage alternative	Total kW	Fuse A
No heating	200 V 3 AC	2.3	16
or Steam heating	208-240 V 1 AC	2.3	16
El heating	240 V 1 AC	12.9	63
	200 V 3 AC	13.4	50
	220-240 V 3 AC	11.1	50
	220-240 V 3 AC	17.5	50
	380-415 V 3N/3 AC	17.5	35
	440/480 V 3 AC	18.9	35
	380-415/220-240 V 3N/3 AC	17.5	35/50
	380-415/220-240 V 3N/3 AC	11.1	35/50
	415/240 V 3N/3/1	18.9/12.9	35/63

W4240H

Heating alternative	Voltage alternative	Total kW	Fuse A
No heating	200 V 3 AC	2.6	16
or Steam heating	208-240 V 1 AC	2.6	16
	480 V 3 AC	2.6	10
El heating	200 V 3 AC	15.5	50
	240 V 1 AC	14.3	63
	220-230 V 3 AC	13.3	50
	240 V 3 AC	14.3	50
	208-240 V 3 AC	18.3	63
	240 V 3 AC	20.9	63
	380-400 V 3N/3 AC	13.3	35
	380-400 V 3N/3 AC	19.4	35
	415 V 3/3N AC	14.3	35
	415 V 3N AC	20.9	35
	440 V 3 AC	22.1	35
	480 V 3 AC	23.9	35
	380-400/220-230 V 3N/3	19.4	35/63
	415/240 V 3N/3	20.9	35/63
	415/240 V 3N/3/1	20.9/14.3	35/63

W4300H

Heating alternative	Voltage alternative	Total kW	Fuse A
No heating or Steam heating	200 V 3 AC	2.1	16
	208-240 V 1 AC	2.1	10
EI heating	240 V 1 AC	14.3	63
	200 V 3 AC	15.6	50
	220-230 V 3 AC	19.4	63
	220-230 V 3 AC	13.3	50
	240 V 3 AC	14.3	50
	240 V 3 AC	20.9	63
	380-400 V 3N AC	13.3	35
	380-400 V 3/3N AC	19.4	35
	415 V 3N AC	14.3	35
	415 V 3N AC	20.9	35
	440 V 3 AC	22.2	35
	480 V 3 AC	24	35
	380-400/220-230 V 3N/3 AC	19.4	35/63
	415/240 V 3N/3	20.9	35/63
	415/240 V 3N/1	20.9/14.3	35/63

How to convert heating elements from 3AC to 1 AC (400-415V 3AC to 230-240V 1AC) on W465H, W475H and W4105H.

- 43
- Take off isolator cover plate and front panel to expose heating elements.
 - Remove the cables A.

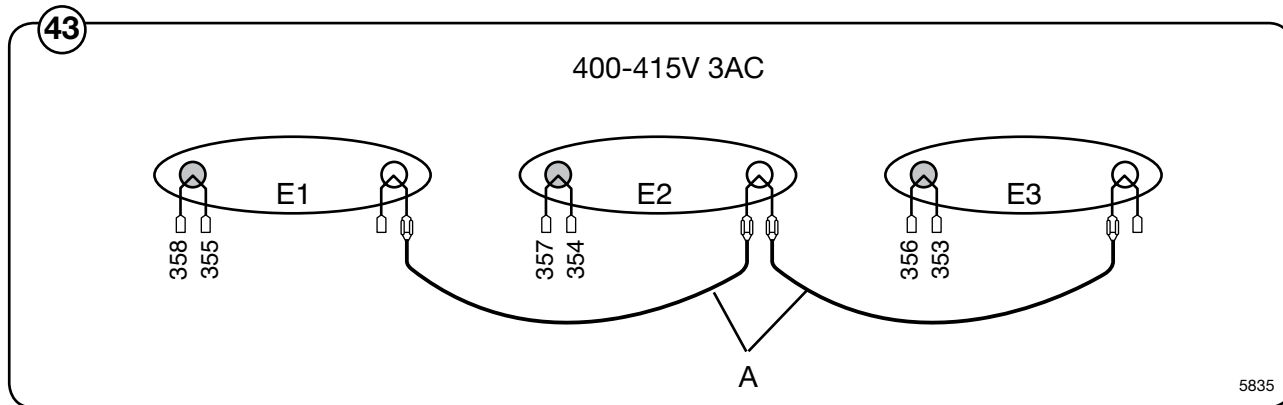

- 44
- Take off wire L3 (A) from terminal L3 on isolator Q1 and from terminal 6 on heating relay K21. Take off wire L2 (B) from terminal L2 on isolator Q1 and reconnect it to terminal N (neutral) instead.
 - The heating elements have coloured insulators on the tips, one is red, the other is white. Connect the ends of the two wires from contactor K21 terminal 1 to the red end of the two elements. These are your element feeds.
 - Connect the ends of the two wires from contactor K21 terminal 3 to the white tips of the two heating elements. These are your neutral returns.
 - Check that all your terminals and wires are secure, then test the machine on a short wash 60°C to ensure that it does heat up.
 - Fasten isolator cover front panel to the machine.

Note!

The wires from terminal 5 on contactor K21 to the redundant heating element can be safely left on.

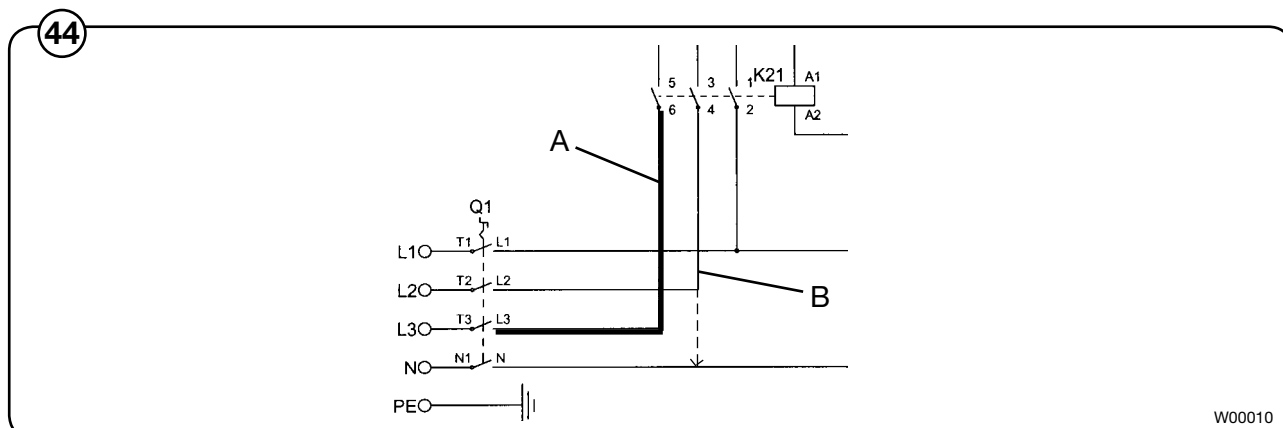

W475S, W485S

Heating alternative	Voltage alternative	Total kW	Fuse A
No heating or Steam heating	200 V 3 AC	0.6	10
	208-240 V 1 AC	0.6	10
EI heating	220-240 V 1 AC	3.4	16
	230/240 V 1 AC	4.4	20
	220-240 V 1 AC	5.4	25
	220-240 V 1 AC	7.3	35
	200 V 3 AC	5.6	20
	220-240 3 AC	3.2	10
	230/240 V 3 AC	4.4	16
	220-240 V 3 AC	5.4	16
	220-230 V 3 AC	7.3	20
	220-240 V 3 AC	7.3	25
	380-415 V 3/3N AC	3.2	10
	400/415 V 3/3N AC	4.1	10
	380-415 V 3/3N AC	5.4	10
	380-415 V 3/3N AC	7.4	16
	440/480 V 3 AC	7.9	16
	380-415/220-240 V 3/3N AC	7.3	16/25

W4105S

Heating alternative	Voltage alternative	Total kW	Fuse A
No heating	200 V 3 AC	0.8	10
or Steam heating	208-240 V 1 AC	0.8	10
EI heating	220-240 V 1 AC	3.2	16
	220-240 V 1 AC	7.4	35
	220-240 V 1 AC	9.6	50
	200 V 3 AC	5.7	20
	200 V 3 AC	7.4	25
	208-240 V 3 AC	9.2	35
	220-240 V 3 AC	3.2	10
	220-240 V 3 AC	7.4	25
	220-240 V 3 AC	9.6	35
	380-415 V 3/3N AC	3.2	10
	380-415 V 3/3N AC	7.4	16
	380-415 V 3/3N AC	9.6	16
	440/480 V 3 AC	8	16
	440/480 V 3 AC	10.5	16
	380-415/220-240 V 3/3N AC	7.4	16/25
	380-415/220-240 V 3/3N AC	9.6	16/35

W4130S

Heating alternative	Voltage alternative	Total kW	Fuse A
No heating or Steam heating	200 V 3 AC	0.7	10
	208-240 V 1 AC	0.8	10
EI heating	220-240 V 1 AC	3.2	16
	220-240 V 1 AC	7.4	35
	220-240 V 1 AC	9.6	50
	230/240 V 1 AC	5.4	25
	208-240 V 1 AC	9.2	50
	200 V 3 AC	5.8	20
	200 V 3 AC	7.5	25
	208-240 V 3 AC	9.3	35
	220-240 V 3 AC	3.3	16
	220-240 V 3 AC	7.5	25
	220-240 V 3 AC	9.7	35
	230/240 V 3 AC	5.4	16
	380-415 V 3/3N AC	3.3	10
	380-415 V 3/3N AC	5.4	10
	380-415 V 3/3N AC	7.5	16
	380-415 V 3/3N AC	9.7	20
	440/480 V 3 AC	8	16
	440/480 V 3 AC	10.6	16
	380-415/220-240 V 3/3N AC	7.5	16/25
	380-415/220-240 V 3/3N AC	9.7	20/35

W4180S

Heating alternative	Voltage alternative	Total kW	Fuse A
No heating or Steam heating	200 V 3 AC	0.9	10
	208-240 V 1 AC	0.9	10
EI heating	220-240 V 1 AC	12.7	63
	200 V 3 AC	10	35
	220-240 V 3 AC	12.7	50
	380-415 V 3/3N AC	12.7	25
	440/480 V 3 AC	13.8	25
	380-415/220-240 V 3/3N AC	12.7	25/50

W4250S

Heating alternative	Voltage alternative	Total kW	Fuse A
No heating or Steam heating	208-240 V 1 AC	1.2	10
	200 V 3 AC	1.2	10
EI heating	200 V 3 AC	13.6	50
	220-240 V 3 AC	12.1	63
	220-240 V 3 AC	17.6	50
	380-415 3N AC	12.1	35
	440/480 V 3 AC	19.1	35
	380-415/220-240 V 3/3N AC	12.1	35/63
	380-415/220-240 V 3/3N AC	17.6	35/50

W4330S

Heating alternative	Voltage alternative	Total kW	Fuse A
No heating or Steam heating	208-240 V 1 AC	1.5	10
	200 V 3 AC	1.5	10
EI heating	240 V 1 AC	14.7	80
	200 V 3 AC	15.8	50
	220-230 V 3 AC	13.5	50
	220-230 V 3 AC	19.7	63
	240 V 3 AC	14.6	50
	240 V 3 AC	21.2	63
	380-400 V 3N AC	13.6	35
	380-400 V 3/3N AC	19.7	35
	415 V 3N AC	14.5	35
	415 V 3/3N AC	21.2	35
	440 V 3 AC	22.4	35
	480 V 3 AC	24.2	35
	380-400/220-230 V 3N/3 AC	19.7	63
	415/240 V 3N/3 AC	21.2	35/63
	380-400/220-230 V 3N/3 AC	13.6	35/50
415/240 V 3N/3 AC	14.5	35/50	

Function checks

Manual operation

- Switch on the machine's main switch.
- Open the manual valves for water and for steam if the machine has steam heating.

In the operating manual, chapter "Manual operation", one can find how to operate the machine manually.

- Check that the drum is empty and close the door.
- Close the drain valve.
- Operate the machine manually to fill with cold water, then hot water. Check that these water supplies are connected as they should be.
- Start the motor on wash action, and check that the motor is revolving clockwise and anticlockwise alternately, as normal for wash action.
- Start heating by entering a final temperature and then pressing **START**. Check that the steam valve opens or the heating element relay reacts, as appropriate.
- Check that all sources of detergent supply are working as they should, including the built-in detergent supply compartments, where present.
- Check the water and steam connections and the drain valve for signs of any leakages.
- Empty the water from the machine and open its door.

Thinking of you
 **Electrolux**

www.electrolux.com/laundrysystems

Share more of our thinking at www.electrolux.com